

Armarios de Obra / IP40

Envolvente protector para línea Aqua Combi especialmente diseñado para armar tableros de obra con parada de emergencia



Paro de emergencia externo



Cierres externos metálicos

CARACTERÍSTICAS GENERALES:

- Alta resistencia al impacto
- Cierres en inoxidable
- Pulsador de emergencia exterior
- Portabilidad

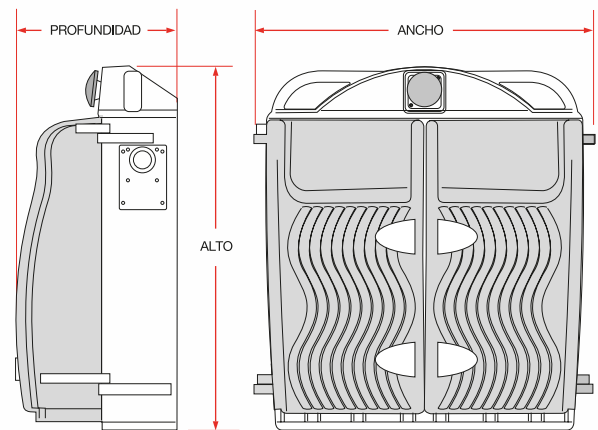
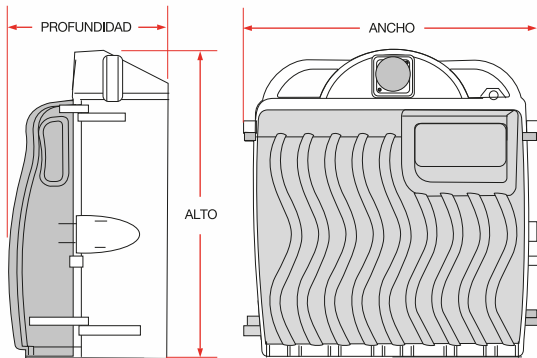

/ ARMARIOS DE OBRA

CÓDIGO	ALTO	ANCHO	PROF.	PESO kg
3979	724	643	419	11
3980	953	890	419	18